



Technology
desking



TRADING

Trading Furniture

Technology Desking.

Established in 1992, Technology Desking specialise in the design, manufacture and installation of furniture products focused on managing technology in the workplace.

From our original UK offices, we have expanded internationally to include additional offices in both Asia and North America. Together with a number of committed alliance partners, we support our customers at a local level anywhere in the world.



TRADING

DT11 - Scalable Desk Frame	6
DT18 - Dynamic PC Enclosure	18
SmartArm	22
Zgo Arm	26
Technology Links	28
Smart Storage	30
Integrated Technology	32
Task Chairs	34
Irys Pod	36
Break-Out	38
Contact	40

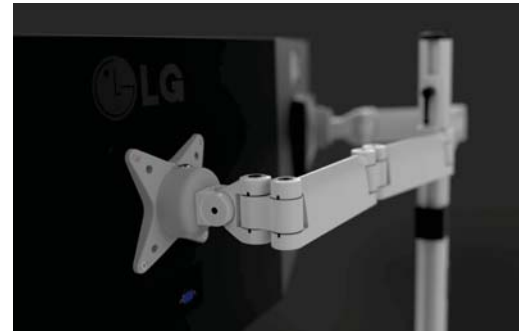



DT11 - Scalable Frame.

One Frame.
Multiple Applications.

DT11 Trading Desks utilise the same frame throughout, enabling us to configure your desk to suit your unique IT requirements. From full-trader to trader-lite, our in-house design team can work with you to create a solution tailored to the challenges faced in your workplace.

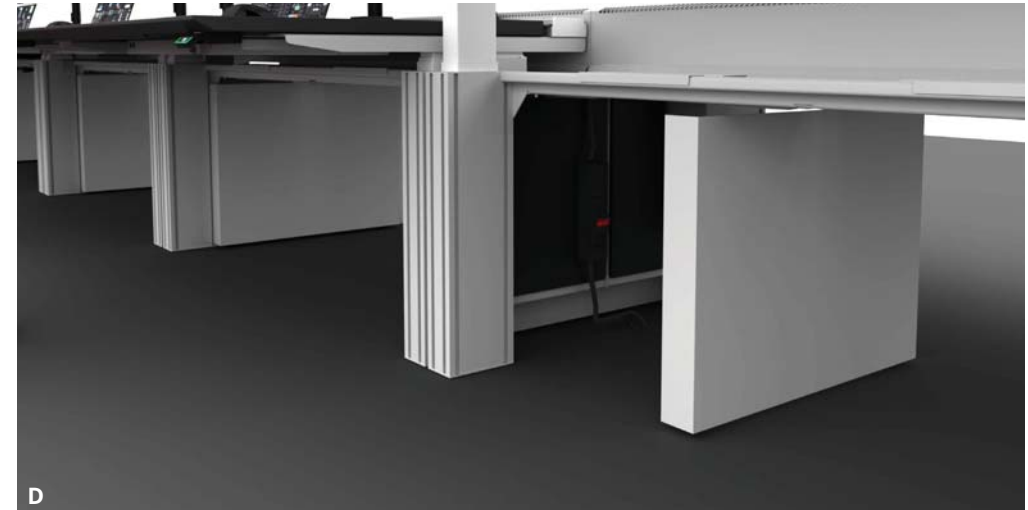
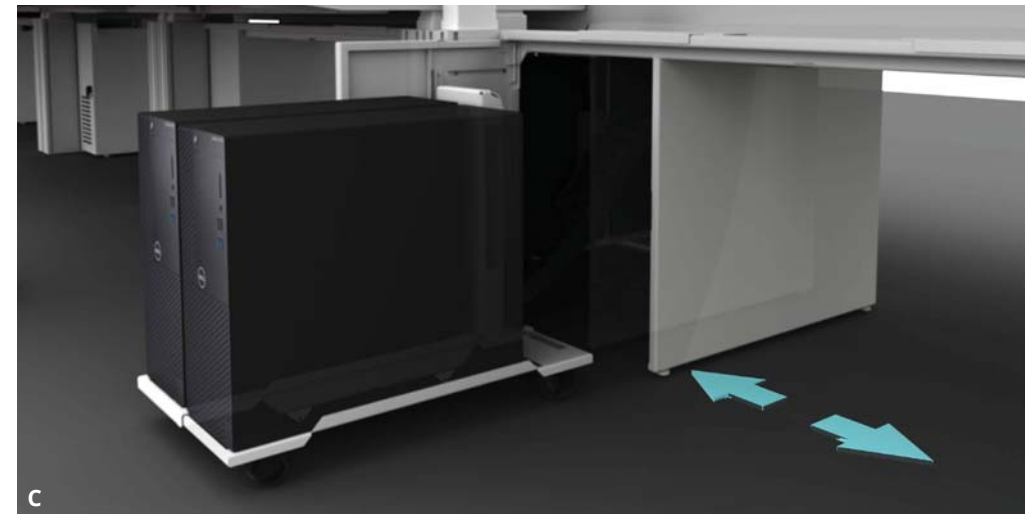
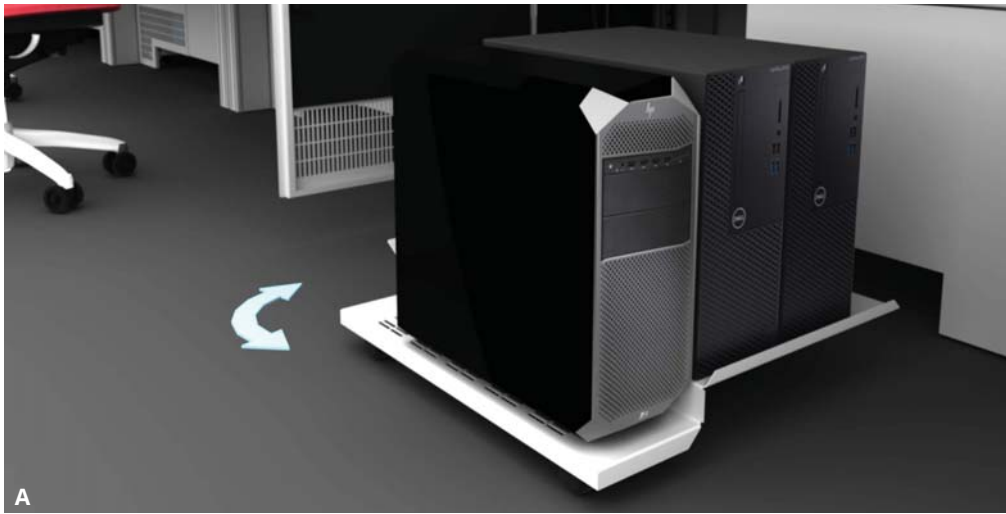

Different Specification.
Same Desk.

Our flexible IT housing solutions enable each user to have a tailored set-up while still keeping the same basic components. All our solutions are designed to achieve maximum ergonomic compliance while offering comprehensive PC storage capacity.



- A Stepped toe space rotating trolley enables you to have one large processor in addition to up to two regular processors while still allowing central toe space for the user.
- B Full toe space rotating trolley houses three regular processors and gives user toe space across the full width of the desk.
- C Expandable PC housing keeps the desk's centre knee well of the desk completely open for the user while enabling a varied PC capacity of between one and two large processors.
- D Termination board covers can be used in situations where remote or thin client PCs are used - opening up the whole knee well to the user.



Cables Managed. Clean Aesthetic.

From desktop to floor, we have earned a reputation for exceptional cable management solutions, regardless of the in-desk requirements.

All our Trading Desks are designed with a high volume of cables in mind. They discreetly house power, data and AV cabling whilst maintaining a clean aesthetic.

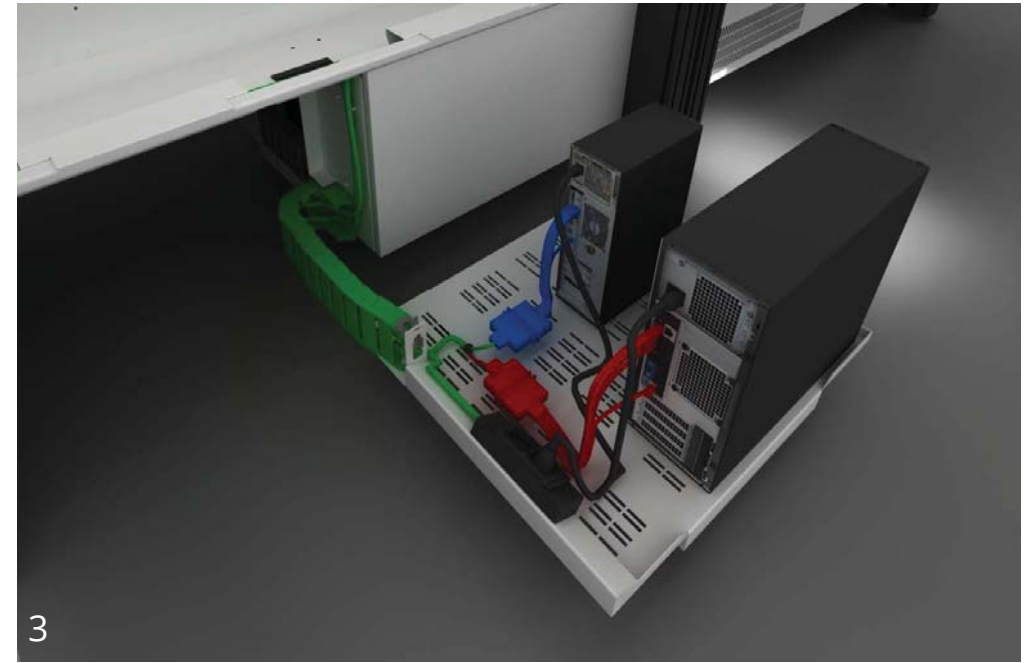
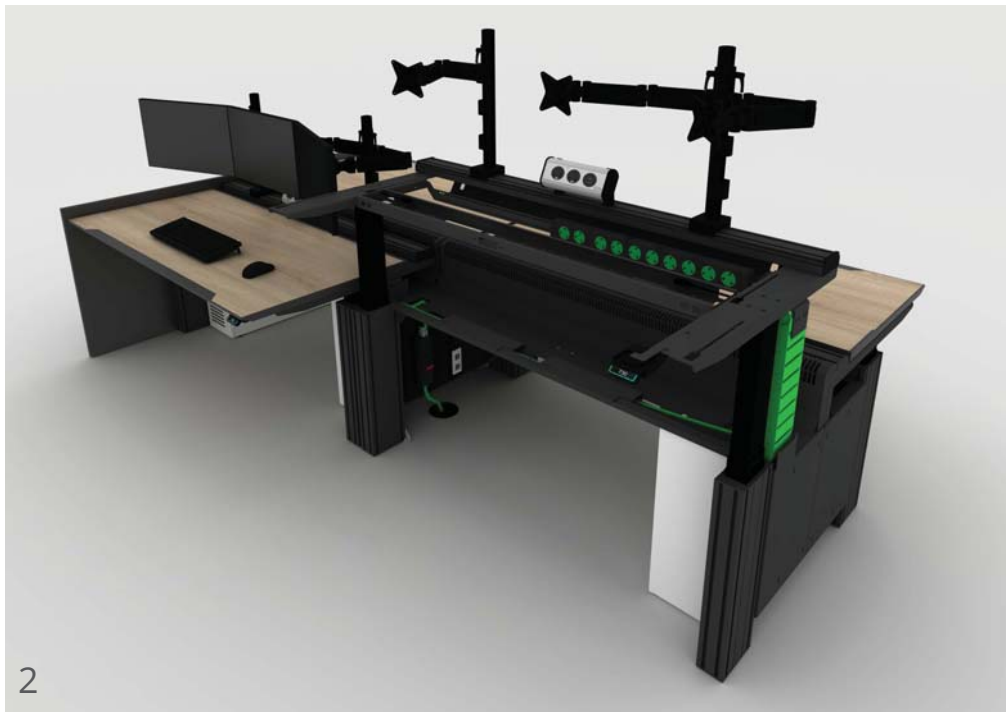
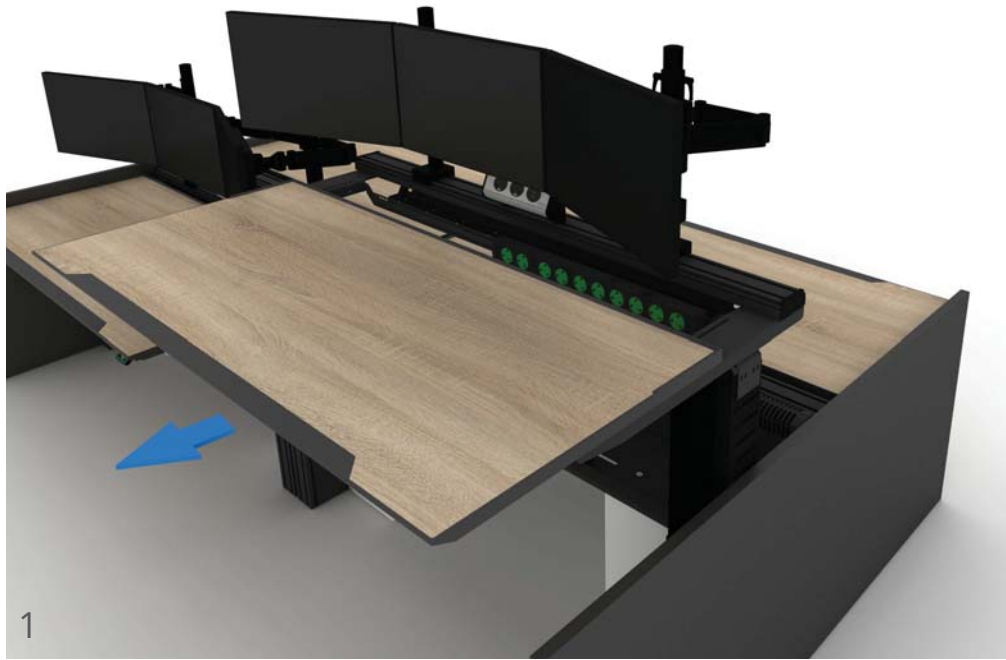

- 1 A sliding desktop gives access to the upper cable tray where sockets are mounted for monitors and desktop peripherals.
- 2 Cables are discreetly managed through the entire desk from the floor to the desktop.
- 3 All PC trollies have a cable management chain that enables quick-release connection. Local power sockets and the use of our Quick Connect looms make moves and changes simple.

Modern Technology.
Premium Functionality.

We utilise the very best in height adjustment technology, both in quality and functionality. Our trading desks boast an adjustment range of 660mm and lower movement noise when compared with market alternatives.

We offer a range of controller styles, from basic up/down controls to advanced LED paddles incorporating Bluetooth connectivity and programmable heights.

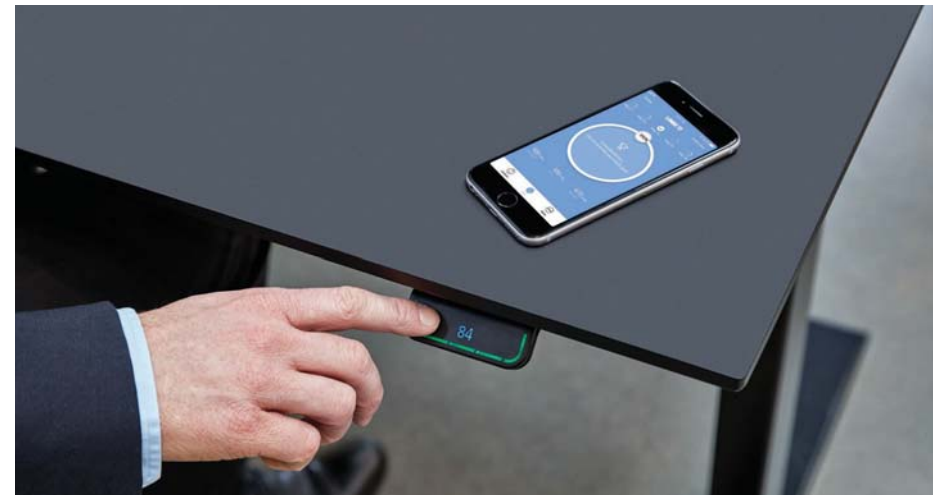

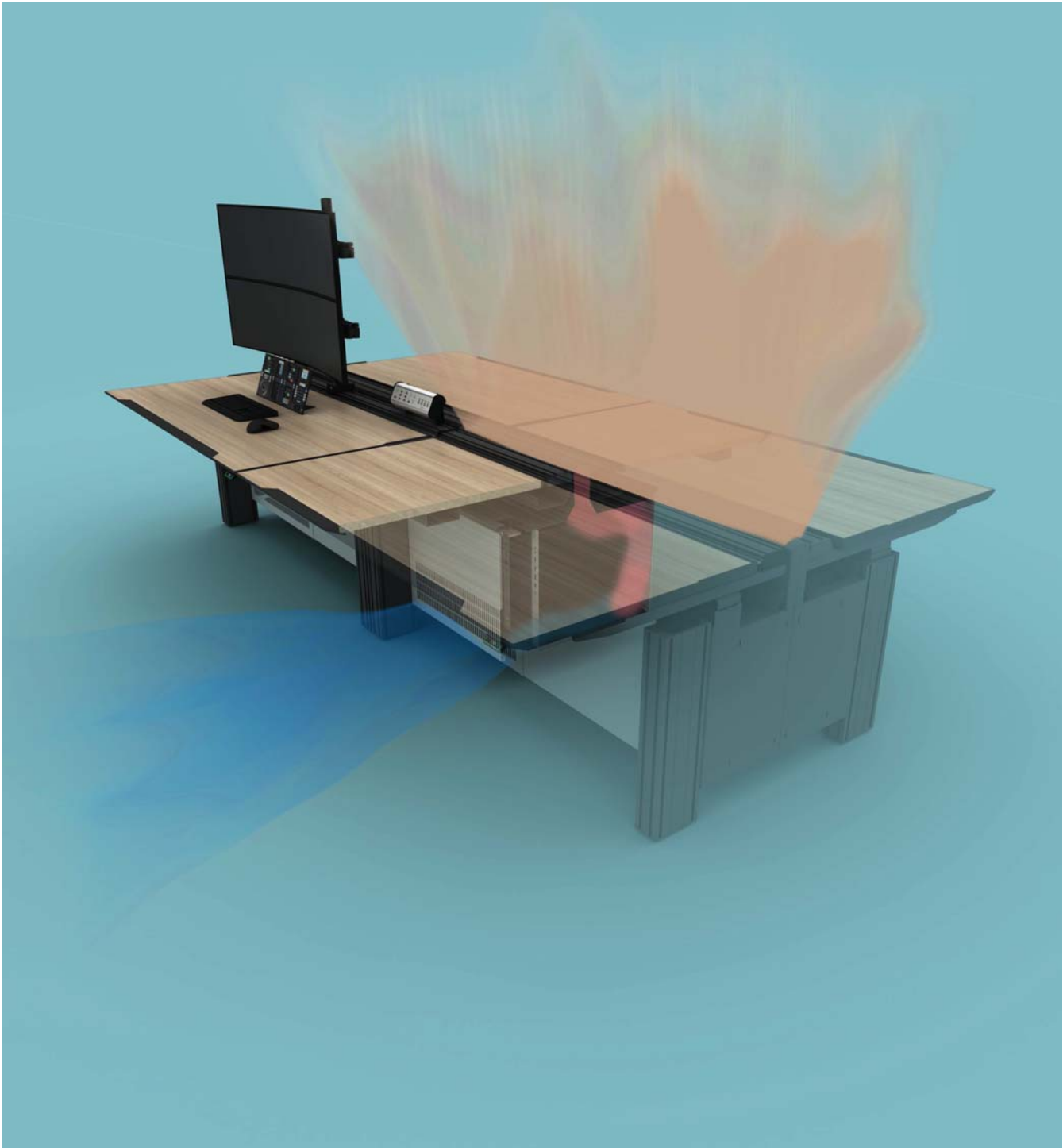

Heat Redistributed. Cooler Desks.

Ventilation is a key factor in the design of all our trading desks.

All our furniture features natural ventilation (A) which encourages cool air from the room to be drawn into the PC enclosure at the lowest point. The hot air generated by the PCs is then expelled back into the room at the rear of the desk, away from the user.

Additionally, we can provide water cooled fan coil cooling. Assisted by fans, the hot air is forced through a water coil before it is released back into the room (B) at the same temperature as the ambient air. This option can be controlled with integration into a building management system.

Please contact us for additional technical information.

A

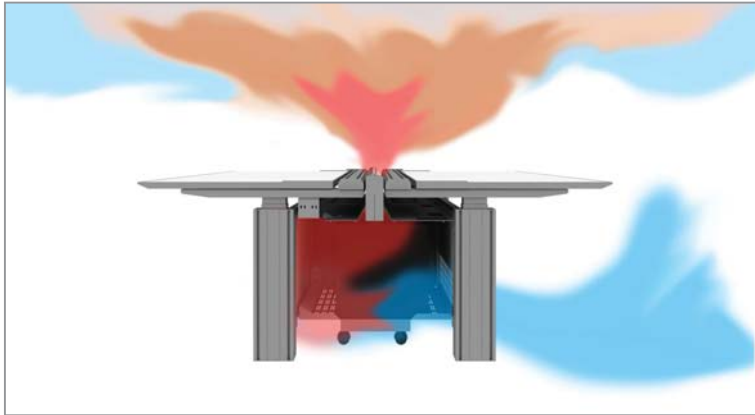

B

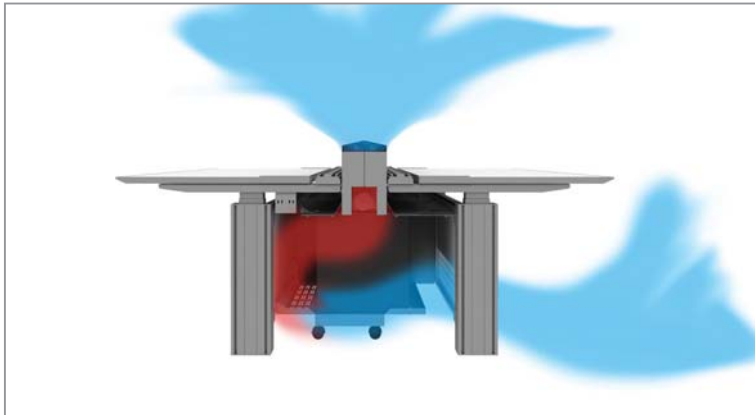



DT18 - Dynamic PC Enclosure.

Lighter Feel. Heavy Duty.

This latest addition to our trading desk family offers a compact solution that minimises the desk footprint and maximises your floorspace. IT requirements such as remote processing or up to two PCs can be stored in the dynamic technology enclosure which moves up and down with the height adjustable desktop. It allows for easier access, simple technology management, and removes the need for bespoke cable lengths. All of this while creating a more open aesthetic.



Plug and play.

A dynamic PC housing minimises the length of connections making DT18 simple to cable and simple to operate.

The size of the PC housing can be specified to your needs, accommodating small form factors or up to two large tower PCs. All this while maintaining open toe space for the user.

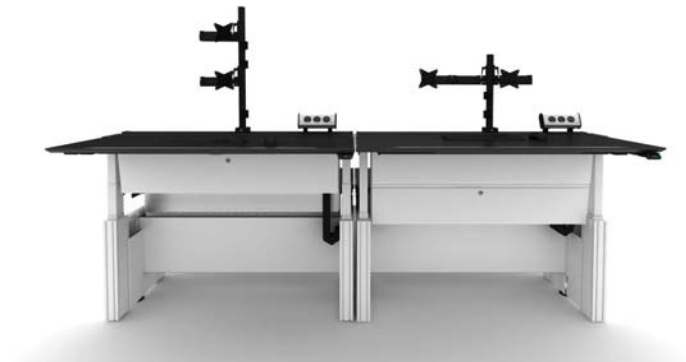



Monitor Arms - SmartArm.

Fully Adjustable, Multi-tier Mounting.

SmartArm is our flat panel monitor mounting system, featuring quick and easy monitor removal, fine height adjustment and complete flexibility.

The system is designed to meet changing monitor specifications and configurations, allowing for either landscape or portrait orientation. Extensions can be added with no disruption to existing monitors.

Our monitor arms offer the perfect solution for layouts with multiple screens.

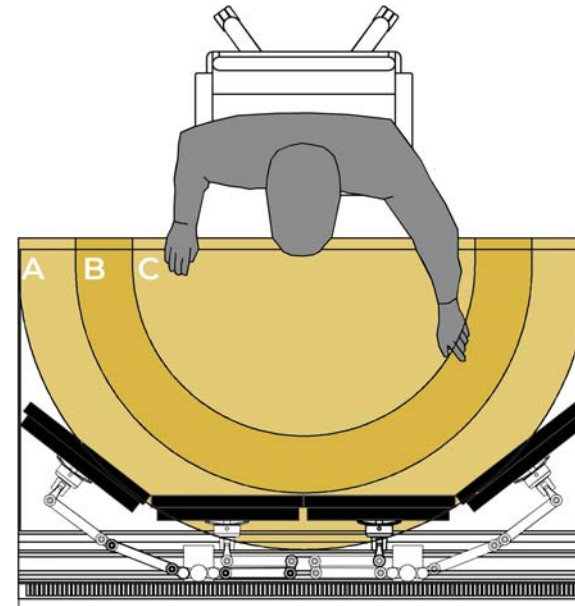
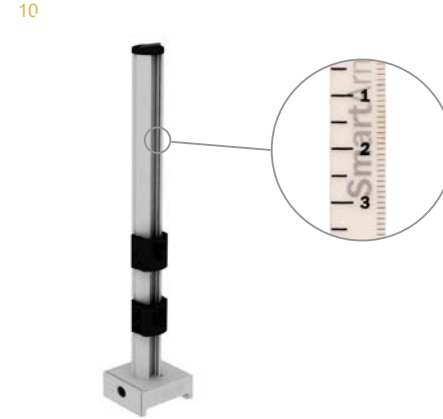
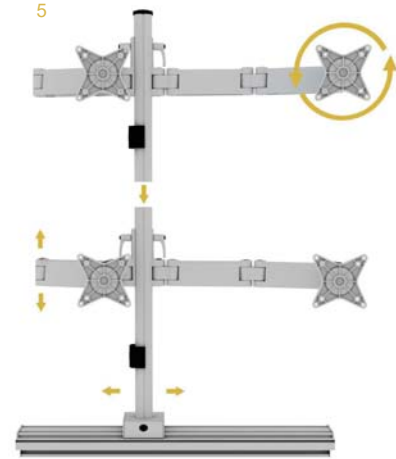
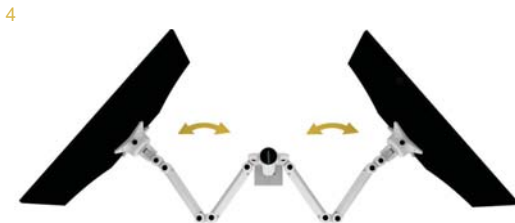
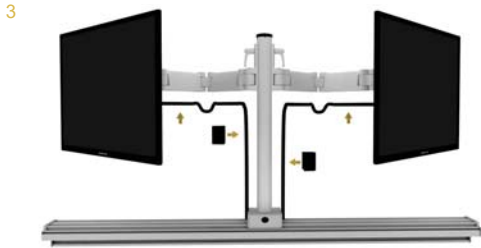
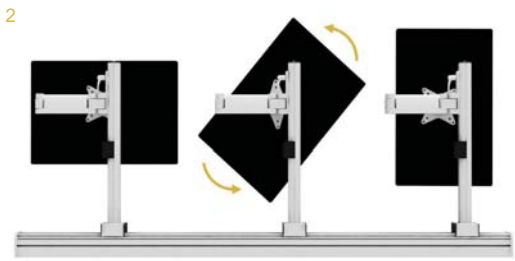
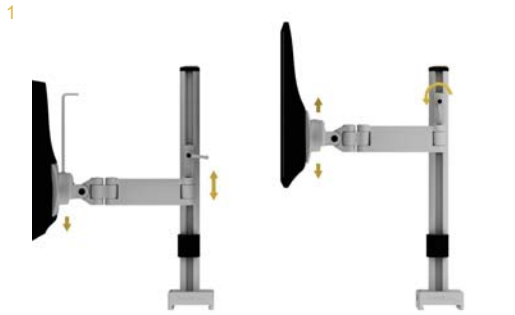

- 1 Fine height adjustment and locking slide bracket.
 - 2 Quick release VESA hub for tilt and swivel monitor movements.
 - 3 Concealed cable management.
 - 4 Arms are configured for maximum adjustability.
 - 5 Reconfigurable system enables you to add and take arms on day two.
 - 6 Monitor rail, through grommet or desk edge clamp mounting options.
 - 7 No link arm
 - 8 One link arm.
 - 9 Two link arm.
 - 10 Integrated ruler so heights can be set to match.
 - 11 Choice of three colours; silver, black and white.
- A Maximum viewing distance: 750mm
 B Optimal viewing distance: 600mm
 C Minimum viewing distance: 450mm

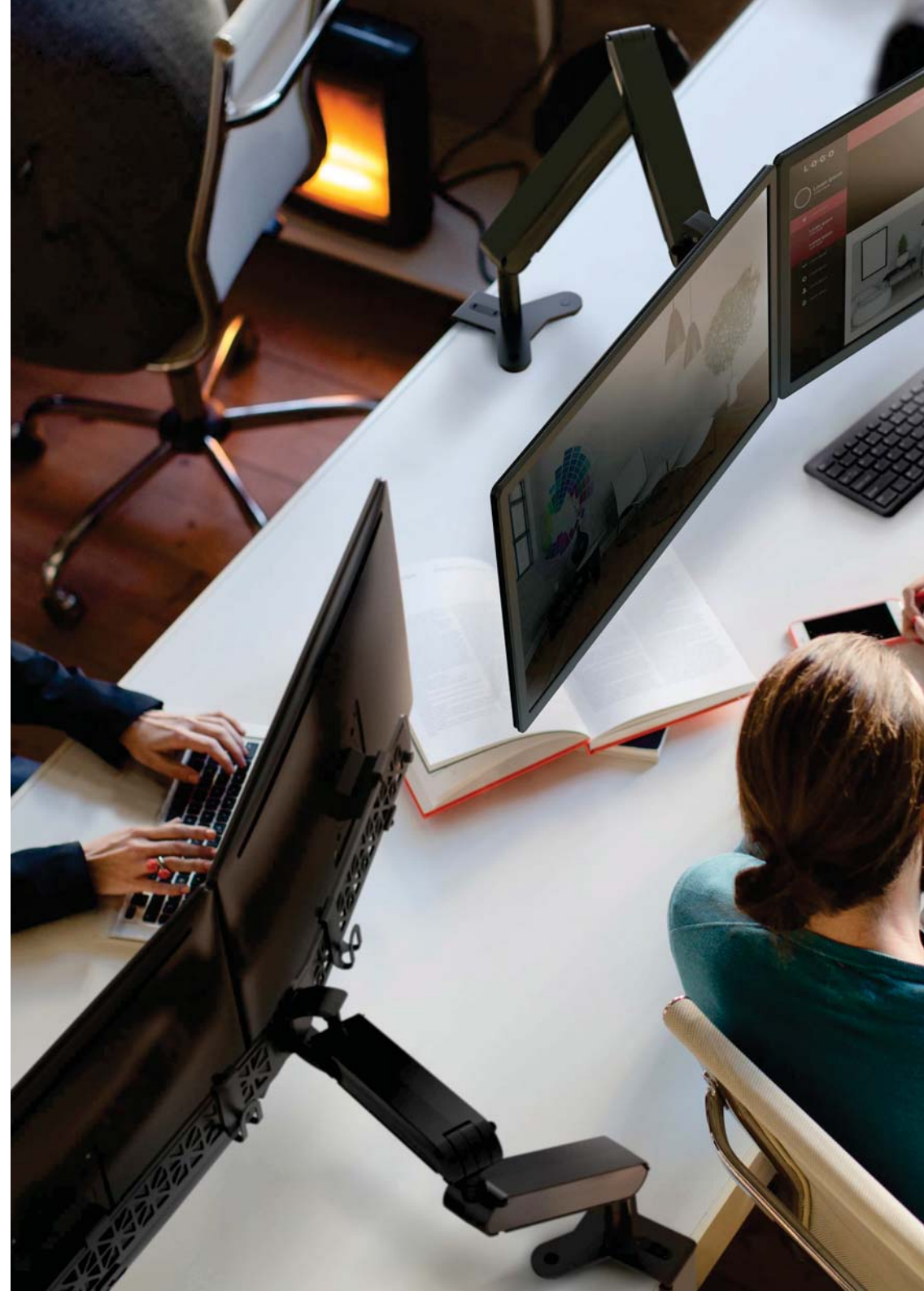
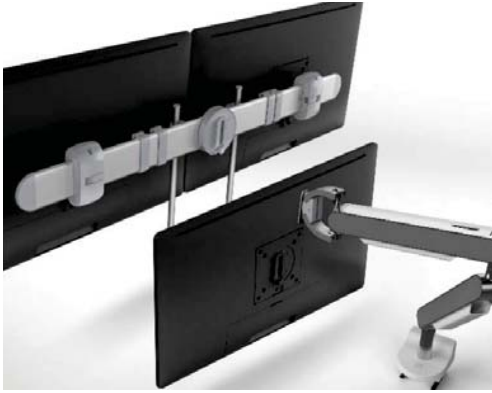
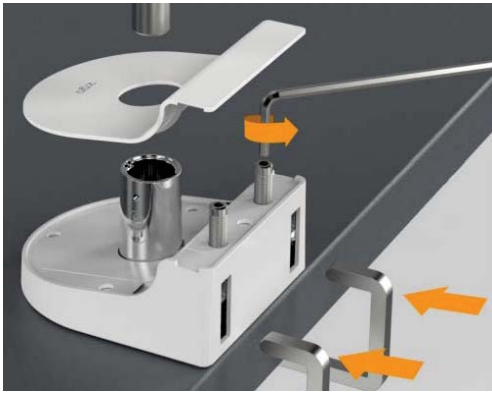

Monitor Arms - Zgo.

Endless Possibilities .

The tension sprung Zgo family of monitor arms provides complete flexibility for the modern office. Featuring the ability to house up to two monitors, the system also provides options for mounting laptops and tablets.

A modular design with fully incorporated cable management coupled with a wide range of colour options and customisable magnetic panels ensure that Zgo can adapt to meet the varying needs of your office while always fitting in with your business identity.

Technology Links.



Unique Connections.

Technology Links is our unique, fully customisable desktop connectivity solution. PC, power and data outlets are replicated at desktop level to enhance user access and speed up connectivity without the need to search awkwardly under the desk. Modules can be tailored to your specific project requirements.

All of our TL modules with PC outlet connections come with the option of 'Quick Connect' looms allowing PCs to be changed in seconds for rapid swap-out, moves and alterations.

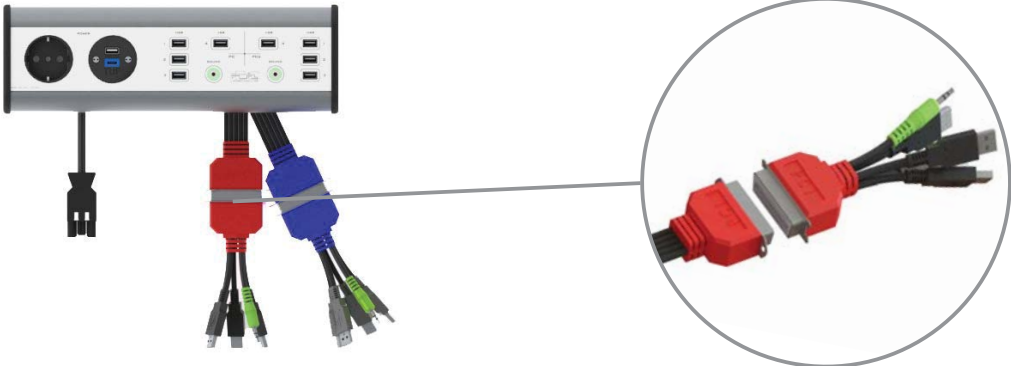



Smart Storage.

Flexible Working.
Reduced Storage.

'Simplicity' keyless locking technology enables a locker to be assigned to an individual when they come into the office, and unassigned again when they leave, with a simple red and green LED light system informing users when a locker is already occupied.

This 'hot-lockering' approach to storage significantly reduces the need for areas dedicated to personal storage within the building.

With Releezme your storage system is connected to the internet enabling users to easily find and access available lockers on their smartphone. This increases flexibility for both the user and facilities management.

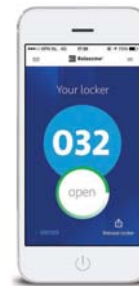

Integrated Technology.

Smart Office.
Smarter Working.

Aura's digital solutions are designed to work natively with commercial displays offering enhanced corporate messaging, streamlined communications and simplified broadcasting.

With room booking management and wireless casting technology, Aura's solutions can integrate throughout your workplace incorporating features such as occupancy sensors to provide real time analytics and space optimisation to reduce overall costs.

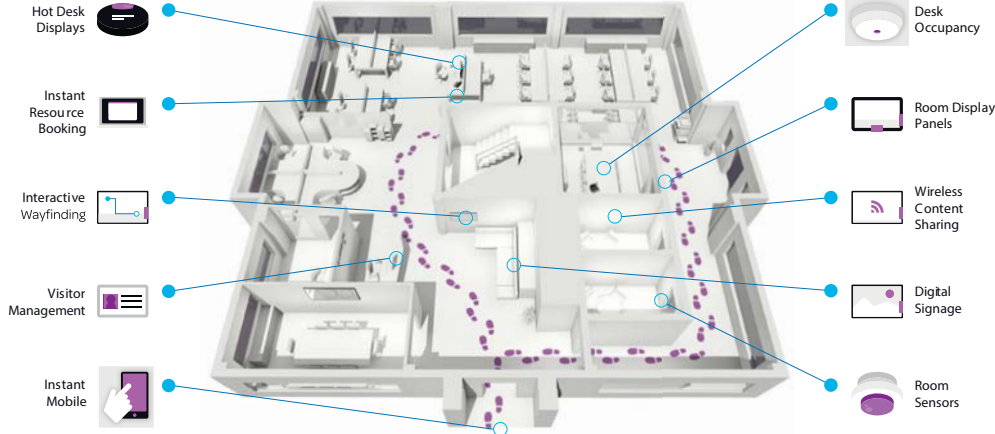



Task Chairs.

You Choose.
We Provide.

We work with a number of partners to offer a select range of 'finishing furniture' for your project

Complete your office with a task chair to provide your workforce with the highest level of comfort.

- A Airpad with Headrest
- B Joyce IS3
- C Vintage IS5
- D Freedom Task
- E Freedom Headrest
- F Liberty Task

Relax. Meet. Collaborate.

The Irys Pod system creates flexible multi-use spaces within your office without the need for planning and with the ability to move, change, and grow with your business.

Whether you're looking for a private office, breakout areas, a meeting room or an informal space, Irys can be tailored to your needs with innovative technology integration and a wide range of finishes.

Irys Pod.



CLESTRA
Hauserman



A



B

Break Out.

Contemporary Working.
Timeless Style.

Add a pop of colour and integrate collaborative furniture into your workspace! We are proud to partner with leading British furniture manufacturer Hitch Mylius supplying high quality, contemporary soft seating, and break-out environments.



C



D



E

- A HM107D High Table with HM58J and K Bar Stools
- B HM991k Sofa
- C HM22A Tub Chair, HM51B2 Stool and HM63H Table
- D HM19 Booth
- E HM44B2 Lounge Chair with G2 Table



Arrange a visit to
your local showroom
today.

EMEA Showroom

Technology Desking Ltd.
Suite 2.01, 30 Harbour Island North
Harbour Exchange Square
London E14 9GE

ukinfo@technologydesking.com
+44 (0) 207 837 3355



North American Showroom

Technology Desking INC.
39 Broadway
Suite 1640
New York NW10006

usinfo@technologydesking.com
+00 (1) 212 257 6998



Asian Sales Office

Technology Desking HK Ltd.
15/F, Hong Kong & Macau Building
156-157 Connaught Road
Central District, Hong Kong

hkinfo@technologydesking.com
+00 (852) 2868 3878



We support projects globally via our regional sales offices. To discover our full range of products or discuss an upcoming project, contact one of our teams.



www.technologydesking.com